



*Catalog*

**CCS**

**Capacitive  
Silicone Sensor**

Voltage Detectors  
for AC Catenary



## Capacitive Silicone Sensor

- ✓ Catenary Voltage Detector **V<sub>AC</sub>**
- ✓ Models until **27,500 V<sub>AC</sub>**
- ✓ **Aluminum** terminals and exterior **silicone** coating
- ✓ Leakage line of **972mm** or **1605mm** for **medium** or **very heavy contamination (MF)** according to IEC 60815-3 application area.
- ✓ Available Outputs:
  - **CBI21** – Output 4-20 mA
  - **FO** – Fiber Optic Output
  - **RS485** Modbus
  - **SMFR** - Semaphore
- ✓ Sensor's weight CCS25: **1,8** or CCS25-MF: **2,8** Kg
- ✓ Full equipment weight CCS25: **2,8** or CCS25-MF: **3,8** Kg
- ✓ **High resistance** against tampering and vandalism
- ✓ Better weight, resistance and shock life compared to epoxy collectors
- ✓ **Stainless Steel** brackets, **waterproof** case and screws with antivibration washers **Nord-Lock®**
- ✓ **Vertical mounting** with M16 **hexagonal screw** adaptable to any installation, optional side bracket
- ✓ Optional SOP-008 for **beam anchoring for vertical mounting**. Adaptable to any installation. Approved by ADIF.



### Models

Model	Voltage Service	Test 1 min 50 Hz	Leakage Line	Pollution Zone	Sensor Height	Sensor Weight
<b>CCS10</b>	10 kV <sub>AC</sub>	50 kV <sub>AC</sub>	618mm	Media	210mm	1,2 kg
<b>CCS10-MF</b>	10 kV <sub>AC</sub>	50 kV <sub>AC</sub>	972mm	Muy Fuerte	300mm	1,8 kg
<b>CCS25</b>	27,5 kV <sub>AC</sub>	95 kV <sub>AC</sub>	972mm	Media	300mm	1,8 kg
<b>CCS25-MF</b>	27,5 kV <sub>AC</sub>	95 kV <sub>AC</sub>	1605mm	Muy Fuerte	356mm	2,8Kg

## Applications

Detection of the presence of **AC voltage** in Railway Installations:

- High Speed Trains
- Conventional trains in AC
- Underground / Subway in AC

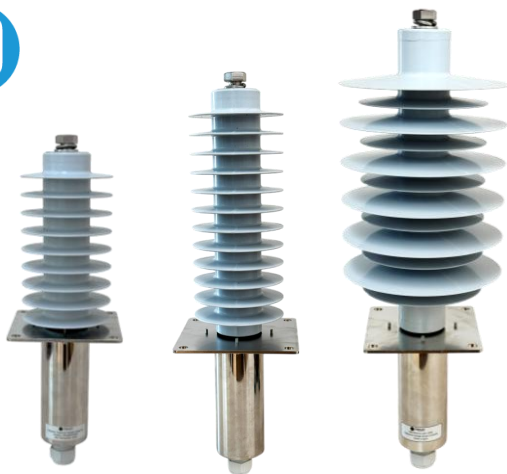

## Measurements

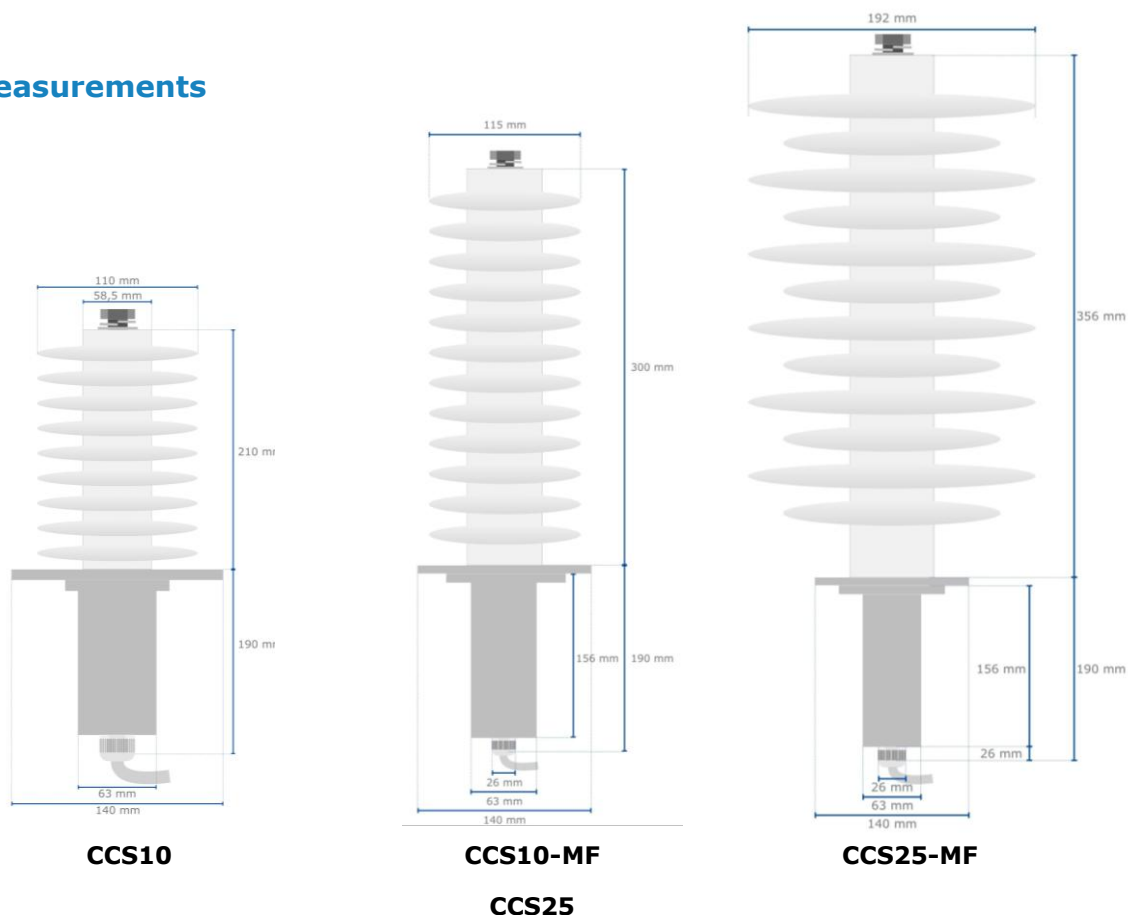

## Technical data

<b>CCS</b>	
<b>Silicone</b>	<b>ISO 37</b>
Elongation Upon Impact	630 %
Resistance to traction	8,5 N/mm <sup>2</sup>

### Support – SOP-008

- Bracket for **mounting beam anchor**
- Adaptable to any installation
- **Approved by ADIF**
- Made of hot-dip galvanized steel **UNE EN ISO 1461**

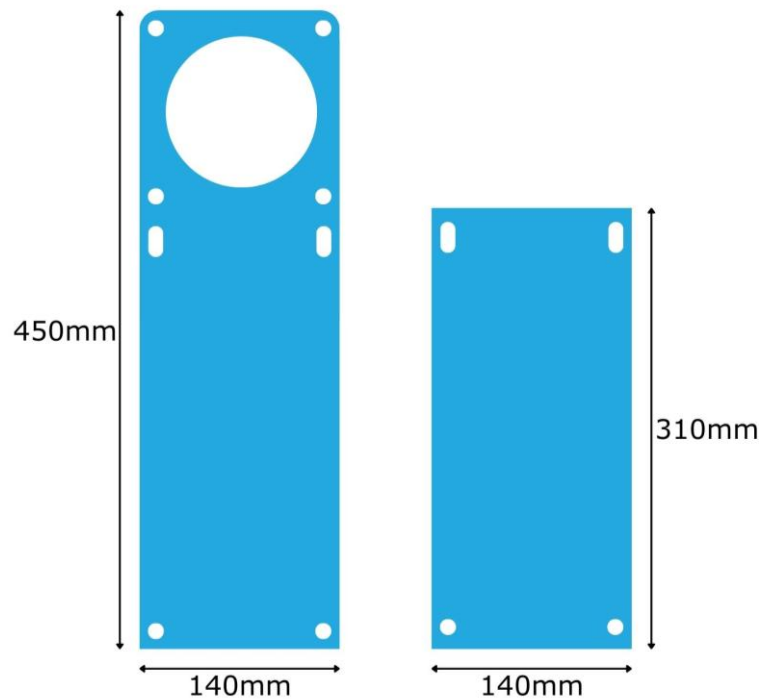
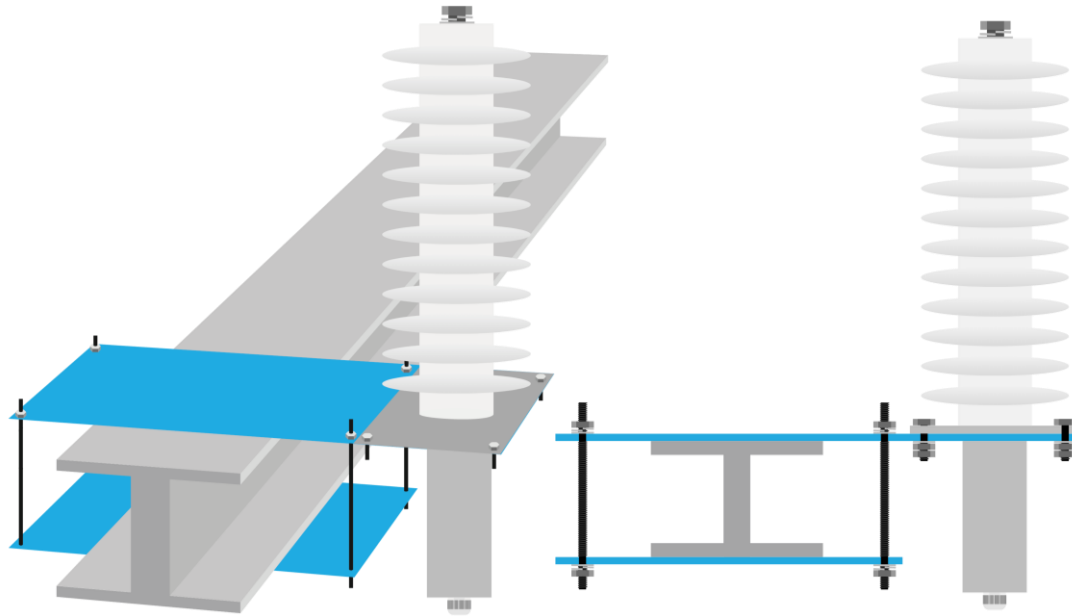

# **CCS + CBI21** Capacitive Silicone Sensor + Output 4-20mA

- ✓ Capacitive Silicone Sensor **CCS**
- ✓ CBI21 **current loop converter** with isolated output **4-20mA** proportional to catenary voltage
- ✓ Measurement 16-60 Hz depending on model
- ✓ Auxiliary voltage **85-264 V<sub>AC</sub> | 85-370 V<sub>DC</sub> , 48 V<sub>DC</sub> , 24 V<sub>DC</sub>**  
Depending on the model
- ✓ CCS25 + CBI21 Supports lightning-like impulses **170kV**
- ✓ CCS25-MF + CBI21 Supports lightning-like impulses **250kV**
- ✓ **Epoxy Coated Circuit** installed in waterproof case



## **Models**

Model	Nominal Frequency	Output	Output 4 – 20 mA	Auxiliary voltage
<b>CBI21</b>	50-60 Hz	4 wires	Yes	85-264 V <sub>AC</sub>   85-370 V <sub>DC</sub>
<b>CBI21-48</b>	50-60 Hz	4 wires	Yes	48 V <sub>DC</sub>
<b>CBI21-24</b>	50-60 Hz	4 wires	Yes	24 V <sub>DC</sub>
<b>CBI21-2H-24</b>	50-60 Hz	<b>2 wires</b>	Yes	24 V <sub>DC</sub>
<b>CBI21-HZ</b>	16-60 Hz	4 wires	Yes	85-264 V <sub>AC</sub>   85-370 V <sub>DC</sub>
<b>CBI21-HZ-24</b>	16-60 Hz	4 wires	Yes	24 V <sub>DC</sub>

Example order: CCS25 + CBI21-24

## ❶ Connection

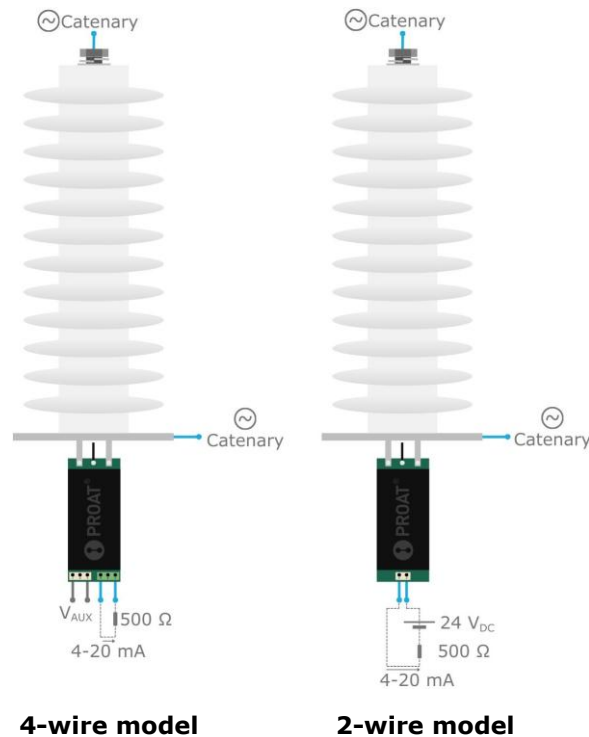

## ❷ Technical data

### CBI21

Specifications	
Output (RL = 500 Ω)	4-20 mA
Maximum load resistance	750Ω
Linearity	1%
Accuracy	±1%
Consumption	3W
Input-Output isolation	3kV
Operating temperature	-30° to +75°

## ❸ Tests

### Tests Norm UNE 61243-1:

- Applied voltage from 0 to 50 kVDC
- Operating time **tests**, according to 6.2.10: Applied voltages: 30 kVAC and then 50 kVAC for 5 minutes.
- **Dielectric test** at industrial frequency 95 kVAC 50 Hz, for 1 minute.
- **Dielectric test**, section 6.3: 15 positive pulses and 15 negative pulses, lightning type 170 KV 1.2us/50us.
- **Climatic test**: from +20°C to -40°C, from -40°C to +20°C, from +20°C to +75°C and from +75°C to +20°C with a 10-hour stay at -40°C and +75°C.
- **Limit test**: Tests have been carried out to determine the extreme voltage that the equipment withstands, reaching 133kV. At that point, the insulator was contoured without causing internal damage. (The equipment was still working properly after the test.)

### Ensayos Norma UNE-EN ISO 9227:

- Corrosion test

# CCS + FO

## Capacitive Silicone Sensor

+

## Fiber Optic Output

- ✓ Capacitive Silicone Sensor **CCS**
- ✓ Fiber Optic Transmitter-Receiver **EFOA25** and **RFOA25**
- ✓ CCS+FO Supports lightning impulse voltages up to **170kV**
- ✓ The set is approved by **ADIF**

### ⓘ EFOA25 – Fiber Optic Emitter

- ✓ Models for:
  - Fiber Optic with **SC connector** up to **100** meters
  - Fiber Optic with **ST connector** up to **5,000** meters
- ✓ Linearity: **±5%**
- ✓ **Auxiliary voltage ±12VDC**

Optional power supply **FA1212-36** of  $\pm 12\text{VDC}$  for input voltages **85-264 VAC | 85-370VDC** with galvanic isolation input/output rated at **36kV**

- ✓ **Epoxy Coated Circuit** installed in waterproof case

### ⓘ RFOA25 – Fiber Optic Receiver

- ✓ With **Real-time display** of catenary voltage for Din Rail models
- ✓ **2 potential-free output contacts:**
  - Voltage Presence – Programmable levels
  - Anomalies – Fiber Optic communication failure
- ✓ **Programmable thresholds** of the presence and absence of voltage contact for Din Rail models
- ✓ **4-20mA** output proportional to the catenary voltage
- ✓ Installation on **Din Rail**
- ✓ Auxiliary voltage **85-264 VAC | 85-370VDC**



### Models – Fiber Optic Emitters

Model	Fiber Optic	Auxiliary voltage
EFOA25	SC Connector	±12V <sub>DC</sub>
EFOA25-LD	ST Connector	±12V <sub>DC</sub>

Example order: CCS25 + EFOA25 with power supply FA1212-36 and compatible receiver RFOA25-D

### Models – Power Supply

Model	Input	Output	Isolation Input-Output
FA1212-36	85-264 V <sub>AC</sub>   85-370V <sub>DC</sub>	±12V <sub>DC</sub>	36 kV <sub>AC</sub>

### Models – Fiber Optic Receivers

Model	Fiber Optic	Compatible Emitter	Installation	Real-Time Visualization	Output 4-20 mA	Output Contacts	Auxiliary voltage
RFO25-D	SL Connector	EFO25	Din Rail	Yes	Yes	Yes	85-264 V <sub>AC</sub>   85-370 V <sub>DC</sub>
RFO25-D-24	SL Connector	EFO25	Din Rail	Yes	Yes	Yes	24 V <sub>DC</sub>
RFOA25-D-LD	ST Connector	EFOA25-LD	Din Rail	Yes	Yes	Yes	85-264 V <sub>AC</sub>   85-370 V <sub>DC</sub>
RFOA25-D-LD-24	ST Connector	EFOA25-LD	Din Rail	Yes	Yes	Yes	24 V <sub>DC</sub>

\*Other models can be manufactured upon request

### Models – Fiber Optic Patch Cords

Model	Connector	Distance
LG-xxx	SC Connector	Models from 5 to 100 meters
LG-xxx-LD	ST Connector	Models from 5 to 5,000 meters

## Connection

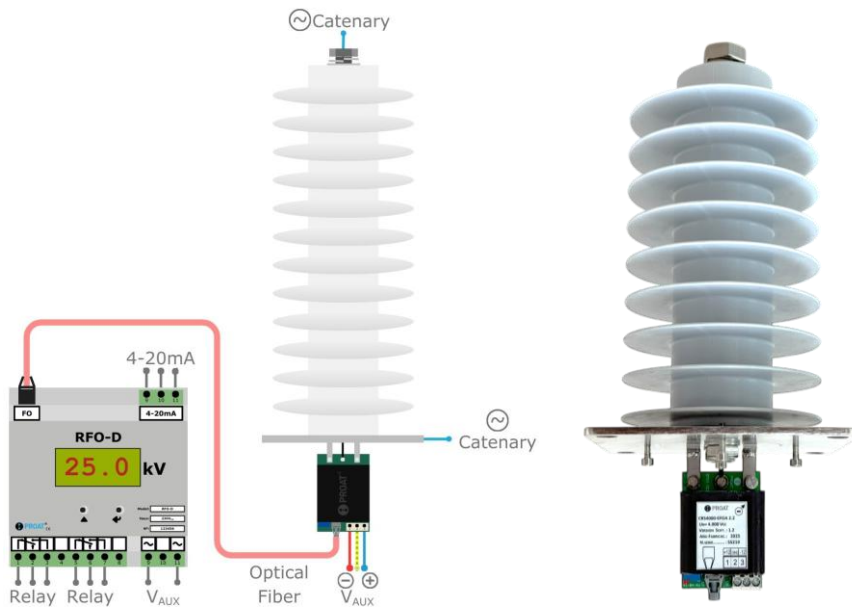

## Technical Data – RFOA25

### RFO-D

Specifications	
Contact Type	SPDT
Switching Capacity:	1000 VA
Switching Voltage:	$\leq 230 V_{AC}$
Response Time	$< 1s$
Reading Range	$0 - U_N + 10\%$
Auxiliary voltage	$85-264 V_{AC}   85-370V_{DC}$ $24V_{DC}$
Standby Power Consumption	$< 5W$
Operating Temperature:	$-10^\circ a +60^\circ$
Regulations	CE

## Constructive Characteristics – RFO-D

- Constructive Characteristics – RFO-D
- Front Plate terminals
- Self-extinguishing plastic case class V0

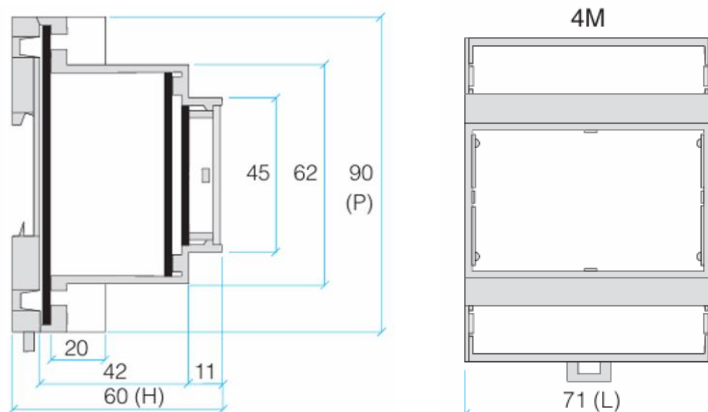

## Power Supply FA1212

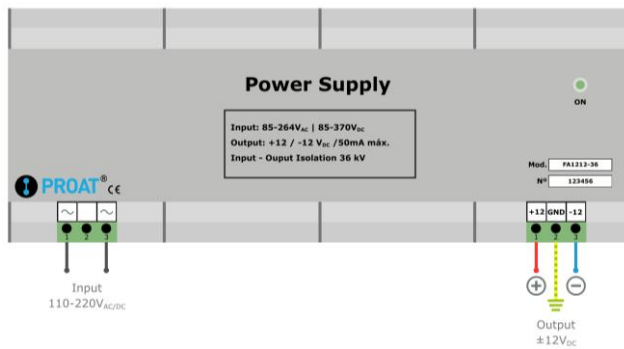

## Constructive Characteristics

- DIN Rail installation
- Front Plate Terminals
- Self-extinguishing plastic case class V0

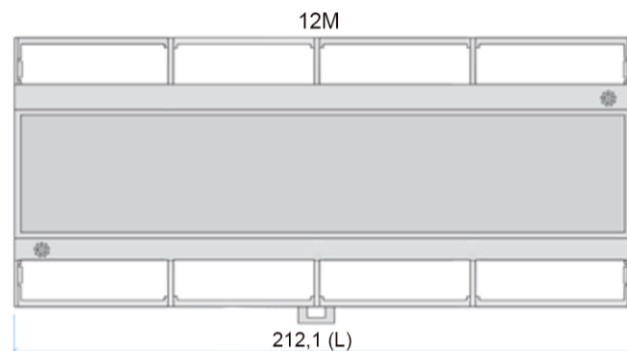
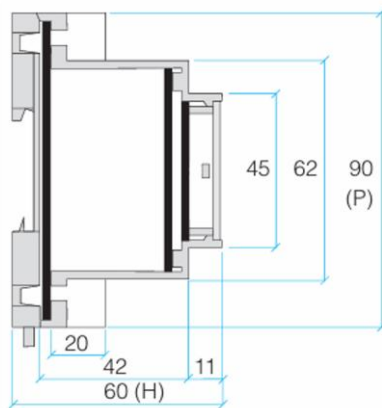

## Tests

### Tests **Norm UNE 21138:**

- Mechanical flexion strength tests: **20N**
- Dry lightning impulse withstands voltage tests

### Tests **Norma UNE 60068:**

- Corrosion test

### Other Tests:

- Operating temperature

# ⓘ CCS + RS485 ModBus

## Capacitive Silicone Sensor

+

## Output RS485 ModBus

- ✓ Capacitive Silicone Sensor **CCS**
- ✓ Voltage and **RS485 ModBus** communications measurement circuit
- ✓ Auxiliary voltage **85-264 V<sub>AC</sub> | 85-370 V<sub>DC</sub>**
- ✓ CCS + RS485 ModBus Supports lightning impulse voltages up to **170kV**
- ✓ **Epoxy Coated Circuit** installed in waterproof case



### 🔑 Models

Model	Auxiliary voltage
RS485-ModBus	85-264 V <sub>AC</sub>   85-370 V <sub>DC</sub>

### 🔑 Connection

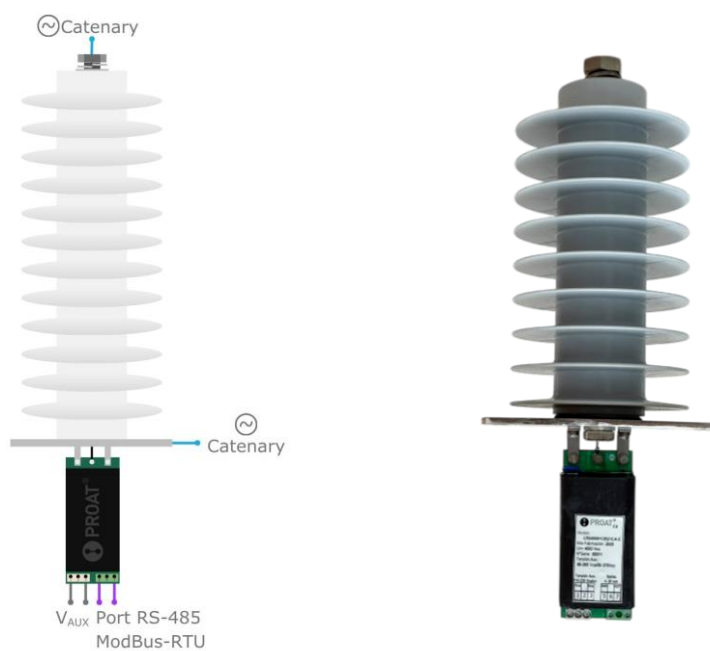

## Technical Data

### RS485-ModBus

Specifications	
Interface	RS-485
Protocol	ModBus-RTU
Parameters	9600, 8, N, 1
ID ModBus	Selectable
Available Features	3,4, 6
Operation	Slave
Cable length (m)	<1200
Response Time	0,2 seg.
Linearity	2%
Precision	±1%
Consumption	2W
Input-output isolation	3kV
Operating Temperature:	-30° to +75°

## Tests

### Tests Norm UNE 61243-1:

- **Applied voltage:** 0 to 50 kV<sub>DC</sub>
- **Uptime Testing**, according to 6.2.10: Applied Voltages of 30 kV<sub>AC</sub> and then 50 kV<sub>AC</sub> for 5 minutes.
- **Industrial Frequency Dielectric Testing** 95 kV<sub>AC</sub> 50 Hz, for 1 minute.
- **Dielectric test**, section 6.3: 15 positive and 15 negative lightning impulses, 170 KV 1,2us/50us.
- **Climate test:** from +20°C to -40°C, from -40°C to +20°C, from +20°C to +75°C and from +75°C to +20°C with 10-hour dwell times at -40°C and +75°C.
- **Limit test:** Tests have been carried out to determine the extreme voltage that the equipment withstands, reaching 133kV. At that point, the insulator surface showed contouring, with no internal damage. (The equipment was still working properly after the test.)

### Tests Norm UNE-EN ISO 9227:

- Corrosion Test

# **CCS + SMFR** Capacitive Silicone Sensor + Green/Red Semaphore

- ✓ Capacitive Silicone Sensor **CCS** + **CBI21** for AC voltage measurement with output 4-20mA
- ✓ Semaphore Green/Red for catenary voltage signaling:
  - Optical LED high **luminosity** in  $\Phi$  200 mm
  - Enclosure color: **Dark Gray**
- ✓ Voltage **Presence Controller PTC-E1**:
  - Reading of the measures **4-20mA**
  - Signage **LED** of the measure
  - Signage **LED Independent** from Ignition and Anomalies
  - Output with **2 Potential-Free Switched Contacts** :
    - Voltage
    - Anomaly
  - Auxiliary voltage **85-264 V<sub>AC</sub> | 85-370 V<sub>DC</sub> or 24 V<sub>DC</sub>**

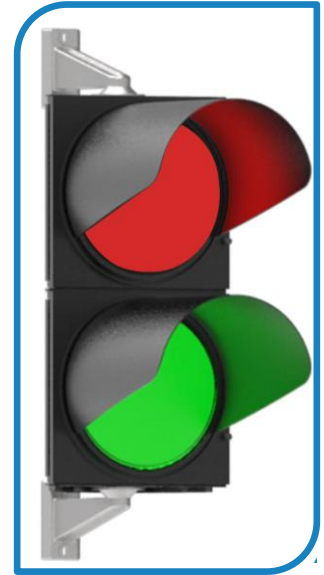

## **Models**

Configuration Options:

- **CCS** - Any Model
- **CBI21** - Any 4 Wire Model
- **PTC-E1** - Voltage Presence Controller PTC-E1
- **SMFR** - Green – Red semaphore
- **Semaphore Support** - Any Model

**Connection**

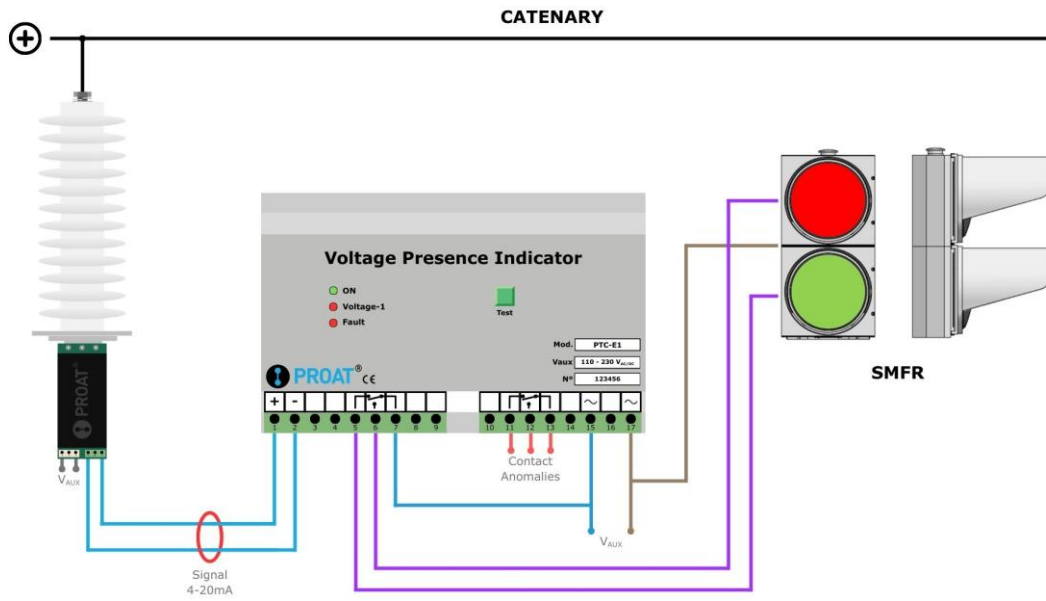

**Constructive Characteristics**

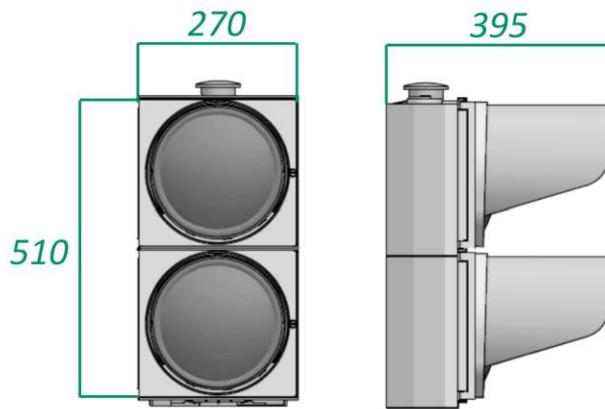

### Support SOP-SMFR-001

- Support for anchoring on **Bracket of diameter 76mm**
- Made of **galvanized steel**

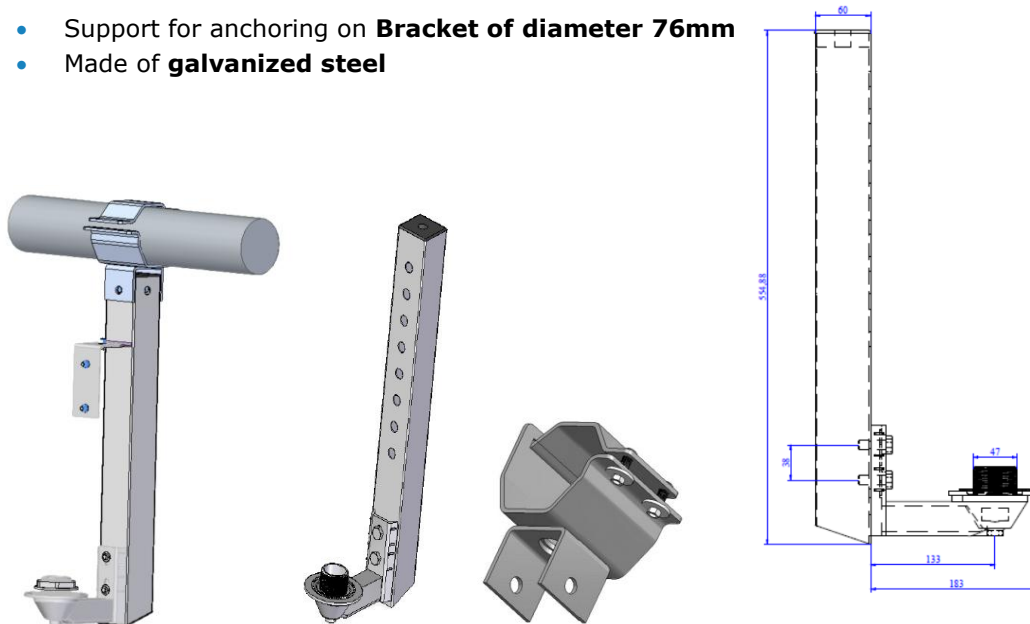

### Support SOP-SMFR-002

- Support for anchoring on wall or **column Ø 100 mm**
- Made of cast **aluminum**
- **Coated in powder polyester** polymerized at 230°C
- Fixing by 2 M-8 screws.
- Internal positioning and anti-rotation serration of the coupled semaphore head.
- Traffic light fixing by sleeve-nut assembly 1½" made of aluminum

#### Advantages

- High mechanical strength
- High resistance to environmental conditions
- Its hollow structure allows the traffic light to be wired through it

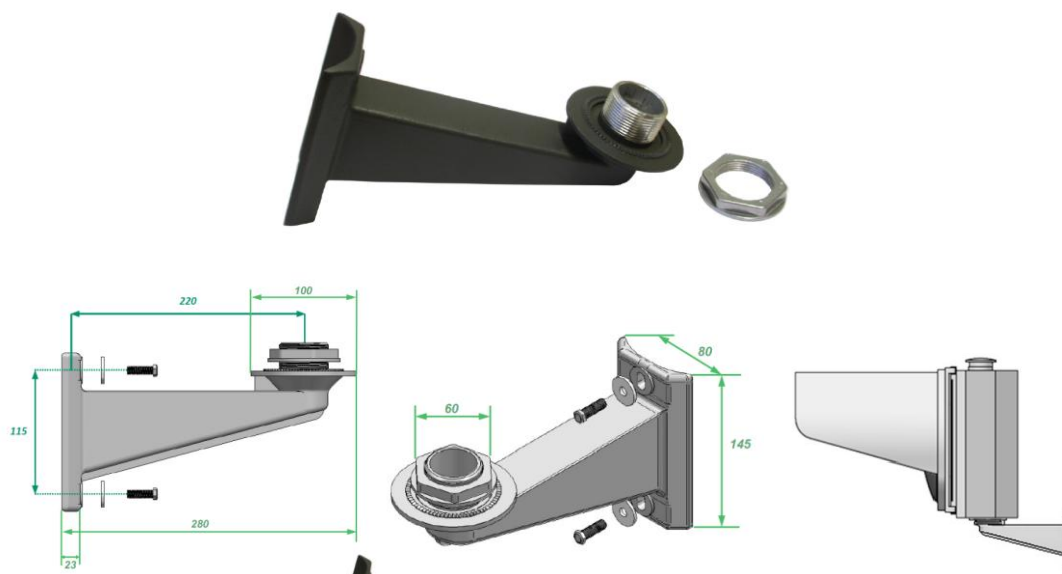

### Support SOP-SMFR-003

- Support for anchoring on **Bracket of diameter 76mm**
- Made of **galvanized steel**

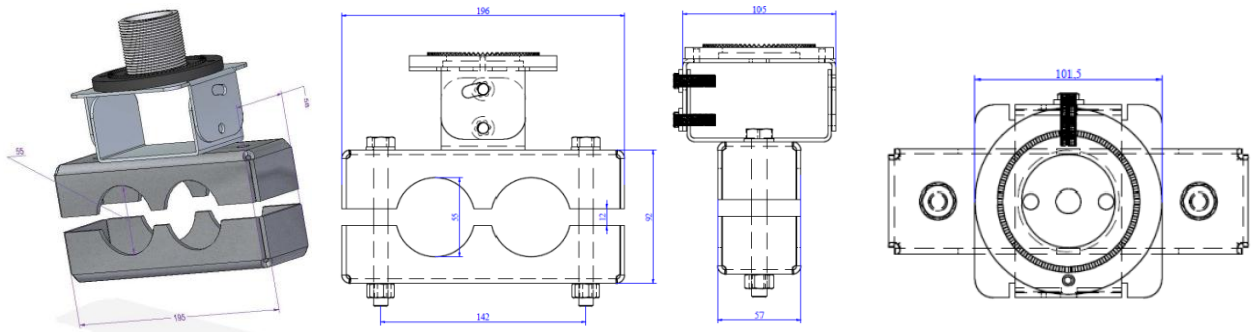

### Support SOP-SMFR-004

- Support for anchoring on **Bracket of diameter 76mm**
- Made of **galvanized steel**

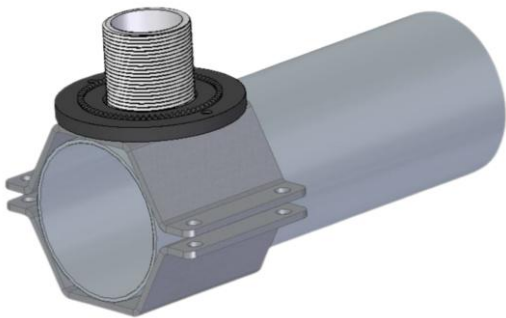

### Support SOP-SMFR-005

- Support for **inverted ceiling anchoring**
- Made of **galvanized steel**

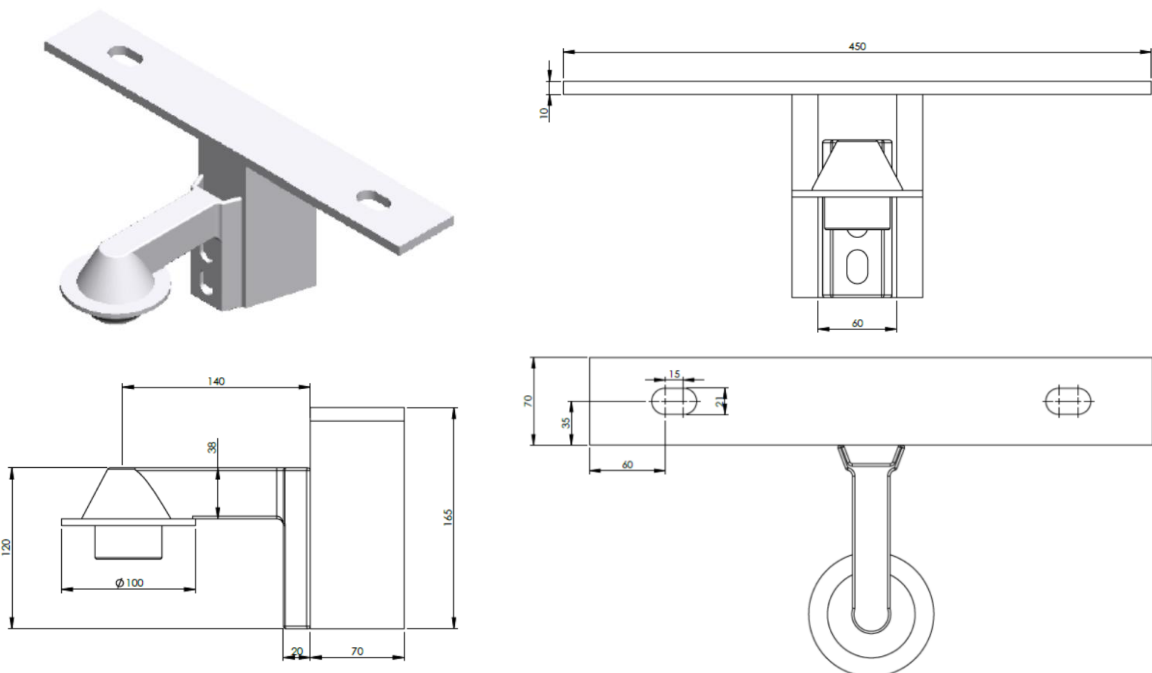

## Support SOP-SMFR-006

- Support for anchoring in **ceiling or vault**
- Made of **galvanized steel**

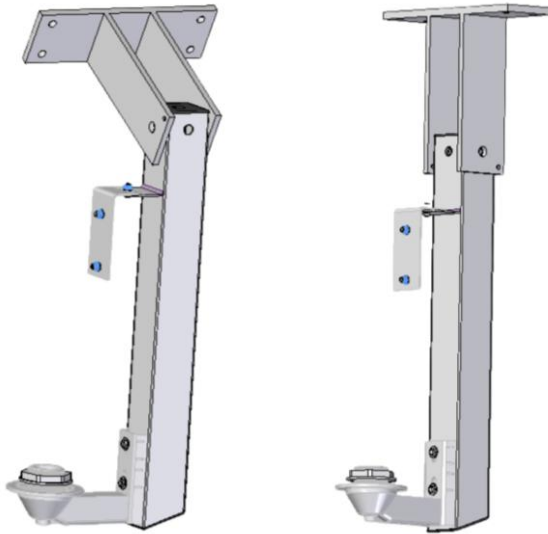

## Technical Data

### SFMR

Case Specifications	
Manufacturing material	U.V. Colored stabilized polycarbonate
Environmental Protection Grade	IP55 (according to EN 60529)
Degree of impact resistance	IR3 (according to EN 60598)
Electromagnetic Compatibility	According to EN 50293
Operating Temperature	-40°C a +60°C
Certificate and marking	According to EN12368
Square Optics (PIL)	200 x 200 mm
Outside Size	270 x 255 mm
LED Colors	Green, Red

### PIL-200x200 PPC

Specifications			
Nominal Voltage	125 V <sub>DC</sub> or 230 V <sub>AC</sub>		
Consumption	< 8W		
Number of LEDs (Red, Amber or Green)	56		
On/off reaction time	< 50 ms		
Environmental requirements (EN 12368 – 5.1)	Class A, B, C (operating temperature of -30°C to + 70°C)		
Electromagnetic Compatibility (EMC)	Meets standard requirements EN50278		
Luminance Distribution (EN 12368 – 6.4)	WA3/1		
Luminance Uniformity (EN 12368 – 6.5)	> 1:10		
Ghost effect (EN 12368 – 6.6) *	Class 4 (Red)	Class 4 (Amber)	Class 5 (Green)
Colors of light signals (EN 12368 – 6.7)	620-630 nm (Red)	587-592 nm (Amber)	502-508 nm (Green)
Environmental Protection Grade (EN 60598)	IP65		
Degree of impact resistance (EN 60598-1)	IR3		
Front Lens Material	Stabilized transparent polycarbonate UV		
Enclosure material	ABS black		

(\*) The ghosting effect occurs in halogen or incandescent traffic lights with the parabolic reflector, due to the reflection of the sun. Drivers could get confused and have the impression that the traffic light is on when it is not.